

Operating Instructions

Continuous-Flow Mixer calypso D30



392595-10/2000

© 2000 m-tec mathis technik gmbh

Copyright in these operating instructions remains with m-tec mathis technik gmbh. These operating instructions are intended for the use of installation, operating and maintenance personnel. They contain technical regulations and drawings which may not be copied, distributed, used for advertising purposes, or communicated to third parties either in whole or in part without authorisation.

Technical development:

The manufacturer reserves the right to adapt technical data without notification in order to reflect the current state of technical development. For information regarding the current status, alterations or additions to these operating instructions, please contact m-tec.

Dear Customer,

this machine represents the current technical state of the art and complies fully with general standards and EC guidelines. This is indicated by the CE symbol and the enclosed declaration of conformity which can be found in the pocket on the machine.

Before using the machine for the first time, please remove the declaration of conformity from the pocket and keep it in a safe place.



Before starting the machine up, fill in the information required on this page. This is the easiest way to familiarise yourself with the characteristics of the machine, and the main data can be consulted at any time without reading them off the machine plate. If you wish to consult us at any time, please have the information on this page ready at hand. The data you require can be found on the machine plate.

Type _____

Machine no. _____

Year of manufacture _____

Power supply _____

Rated current (total) _____

Date of commissioning _____

Application _____

1	Safety	5
1.1	Danger symbols.....	6
1.2	Safety at work.....	7
2	Description of the Machine	10
2.1	Intended use.....	10
2.2	Function	10
2.3	Machine diagram.....	12
2.4	Operating elements	14
2.5	Water supply.....	15
2.6	Technical data	16
2.7	Symbols on the machine.....	17
2.8	Components supplied	17
3	Transport and Set-up	18
3.1	Transport.....	18
3.2	Setting the machine up	19
4	Start-up	20
4.1	Electrical connection	20
4.2	Water connection	21
4.3	Direction of rotation	22
4.4	Setting water flow	23
5	Operation	24
5.1	Using material in bags	24
5.2	Using material from hopper.....	25
5.3	Intervals in work.....	26
5.4	Operation in winter.....	26
5.5	Finishing work.....	27
6	Cleaning	28
6.1	Cleaning after finishing work.....	28
6.2	Cleaning before material change.....	30
7	Maintenance	31
7.1	Lubrication plan	31
7.2	Oil change.....	32
7.3	Maintenance of water filters.....	33
8	Troubleshooting	34
9	Spare parts/accessories	36
9.1	Accessories	36
9.2	Spare parts.....	37
10	Circuit diagram	38

1 Safety

The Continuous-Flow Mixer D30 has been designed, built and tested using the latest technology and has left the manufacturer's plant in perfect condition with regard to safety. However, it may be dangerous to persons or property if used incorrectly, for the wrong purpose, or by untrained personnel. For this reason, persons involved in starting up, operating and maintaining the machine must read and understand the operating instructions beforehand, in particular the section entitled "Safety". This will avoid damage and ensure efficient operation of the machine.



The operating instructions must be kept in the special pocket on the machine at all times, so that the user is able to consult them when necessary.

Modifications to the machine are prohibited. Only spare parts, accessories and lubricants approved by m-tec mathis technik gmbh should be used for the machine.

1.1 Danger symbols

In these instructions, the following symbols are used to draw the attention of the user to possible sources of danger:



Warning!

This symbol is used to identify all operations which may result in serious injury if not carried out correctly. Follow the instructions for work and always proceed with special care. Pay particular attention to the safety of other persons in the vicinity of the machine and its components.

ATTENTION!

Attention!

This symbol is used to identify all work which may involve danger to the material or the machine, or which may affect the efficiency of the process. Follow the instructions closely at all times.

Do not touch!

Moving or rotating parts! Do not put your hands into the machine when it is in operation!



Environment!

This symbol is used to identify potential dangers, which, if disregarded, may endanger the environment.



Use only RCD automatic circuit breakers with the symbol shown opposite.



Info!

This symbol is used to identify important or additional information on the machine or its documentation.

1.2 Safety at work

When transporting, assembling, dismantling, operating, cleaning, and servicing the machine, the applicable national and international safety regulations and legislation must always be observed, even if such regulations and legislation are not explicitly mentioned in these instructions.



In addition, always follow the instructions given below:

- Before working on electrically powered machinery, always switch it off and disconnect it from the mains electricity supply. Even when the machine is switched off, certain parts of it remain live.
- Use only spare parts and accessories supplied by m-tec. m-tec mathis technik gmbh will not accept liability for injury or damage caused by the use of non-approved spare parts and accessories.
- If the machine is being moved by crane or truck, always observe the following points:
 - Before moving it, remove any material remaining in the material trough of the machine
 - Lifting gear (e.g. rope or belt) must have a minimum load-bearing capacity of 400 kg.
 - Attach belts in such a way that they cannot slip.
- The machine must be set up on an even surface and secured against accidental movement.
- It must be positioned in an area where no objects can fall onto it from above. If this is not possible, the machine must be protected by a roof.
- The machine must be positioned in such a way that its operating elements are freely accessible at all times.
- Before every start-up, the continuous-flow mixer D30 must be checked for damage to electric cables, water hoses, plugs and couplings. Any damage must be repaired before the machine is used.

- When the machine is plugged into the power supply, do not put your hands into the machine or the mixing pipe. This may cause serious injury.
- The continuous-flow mixer must be connected to a regulation site distributor box with RCD automatic circuit breaker. Use a 16A 5-pole 6h plug. The connecting cable must have a cross section of 5 x 2.5 mm² and a 16A fuse.
- The Troubleshooting Table is not intended to replace the detailed instructions in the appropriate sections of these Operating Instructions. Always comply with the safety notes in each section!
- Check the direction of rotation of the motor.
- The direction of rotation of the shaft must correspond to the direction of the arrow on the Continuous-Flow Mixer D30.
If the direction is incorrect, switch the machine to "0" immediately at the red main switch and pull out the power plug.
- The maximum operating pressure of the water pump (option) must not exceed 10 bar.
- Intervals in work should be limited in length. Always keep the setting time of the mortar in mind. Hardened mortar in the mixing pipe causes difficulty in starting the motor and may damage the mixer permanently. For longer intervals in work, ensure that the water fitting is completely emptied.
- The machine may be seriously damaged if the water in the fittings is allowed to freeze. At low temperatures, all the water fittings in the machine must be emptied. For longer intervals in work, ensure that the water fittings are completely emptied.
- Close all the draining valves before starting the machine up again.
- Keep the shaft coupling clean, dry and free of grease.

- Do not allow water to enter the material trough or the portioning tube.
- Do not use thin or runny material. Allow it to run into a bucket and dispose it of correctly.
- Do not top up with gear oil between oil changes. If the machine is overfilled with oil, it may overheat. Never mix different types of oil. This may cause the oils to decompose and lead to irreparable damage to the gear unit.
- When disposing of oil, grease and cleaning agents, always comply with the environmental regulations in force.
- Always dispose of empty bags in accordance with environmental regulations.
- Always dispose of mortar residues in the correct way.

2 Description of the Machine

2.1 Intended use

The Continuous-Flow Mixer D30 is suitable for universal mixing of dry mortars which have been pre-mixed by the manufacturer. The Continuous-Flow Mixer D30 can be used for:

- masonry mortar
- various rendering plasters
- adhesive mortar
- floor cement
- fine concrete



It is prohibited to use the machine for any other purpose.

2.2 Function

In its standard form, the Continuous-Flow Mixer D30 is designed for processing bagged mortar material.

The material is poured into the material trough. The portioning screw carries the material from the trough into the mixing pipe where it is mixed with water and conveyed to the discharge outlet.

To prevent fluctuations in pressure in the water supply from affecting production, the Continuous-Flow Mixer D30 can be fitted with a water pump. At low supply pressures, the pressure-increasing pump (which also has a pressure reducer) keeps the water pressure constant at 2 bars.

The required quantity of water is set manually at the fine-control valve and can be monitored using the flow meter (optional extra).

When fitted with a filter hood (optional extra), the Continuous-Flow Mixer D30 can also be used for hopper material (see "Spare parts and accessories").

2.3 Machine diagram

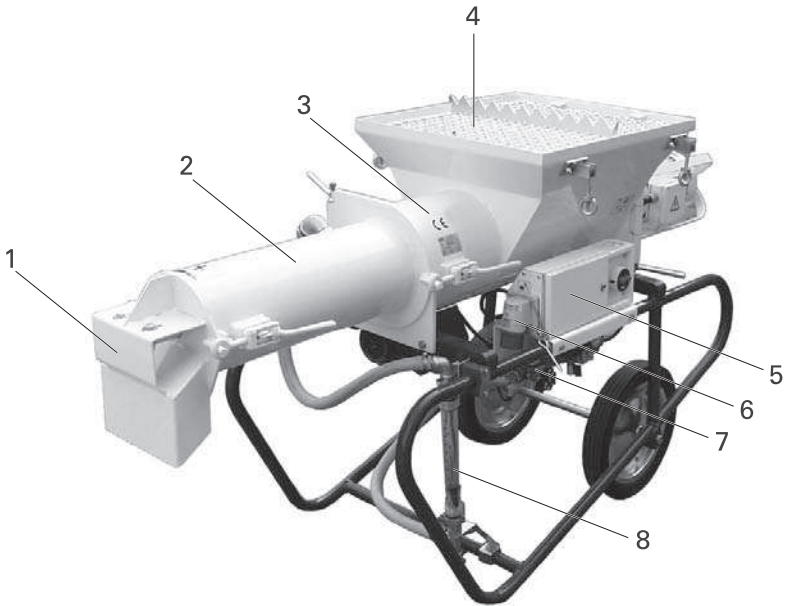

Fig. 1: Front view

- 1 *Bearing cover with outlet*
- 2 *Mixing pipe*
- 3 *Portioning pipe*
- 4 *Material trough with safety grid*
- 5 *Switch cabinet (see page 14)*
- 6 *Input socket*
- 7 *Water fitting*
- 8 *Flow meter (optional)*



Fig. 2: Rear view

- 1 Mixer motor
- 2 Machine-internal water connection
- 3 Water pump (optional)



Fig. 3: D30 with filter hood (optional)

2.4 Operating elements

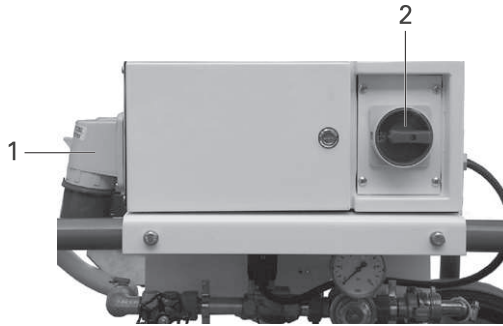

Fig. 4: Switch cabinet

- 1 *Input socket with phase inverter*
- 2 *Main switch with undervoltage trigger (USPA)*

Main switch with undervoltage trigger (USPA)

In position "0", the entire machine is free of voltage. In position "1", the machine is ready for operation. The undervoltage trigger (USPA) is integrated in the main switch. It is a safety feature which switches the machine off when the voltage drops.

2.5 Water supply

The machine requires a constant water pressure of 2 bars.

ATTENTION!

The maximum operating pressure of the water pump (optional) of 10 bars must not be exceeded!

To prevent fluctuations in pressure in the water supply from affecting operations, the Continuous-Flow Mixer D30 can be fitted with a water pump (optional). The water pump increases the pressure and then controls it at constant 2 bars using a pressure reducer.

The required quantity of water is set manually at the fine-control valve and can be monitored using the flow meter (optional extra).

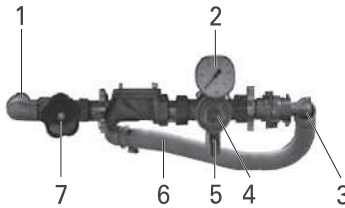

Fig. 5: Water fitting

- 1 Water outlet to mixing pipe
- 2 Pressure gauge
- 3 Water inlet of fitting
- 4 Pressure reducer
- 5 Draining valve
- 6 Water hose from the water pump (optional)
- 7 Fine control valve

The machine may be seriously damaged if the water in the fittings is allowed to freeze. At low temperatures, all the water fittings in the machine must be emptied. For longer intervals in work, ensure that the water fittings are completely emptied.

ATTENTION!

2.6 Technical data

Mixing capacity	approx. 30 l/min (additional equipment see section 9)
Drive motor	3 x 400 V, 50 Hz, 4 kW, 260 r.p.m.
Electrical connection	400 V, 50 Hz fuse 16 A via RCD circuit breaker (site distributor box), power cable 5 x 2,5 mm ² , connected load 11 A
Water connection	3/4" water hose with GEKA-coupling (supplied)
Dimensions	L x W x H: 1,970 x 690 x 1,077 mm (incl. filter hood: H = 2,090 mm or 2,600 mm, depending on type)
Weight	220 kg (incl. filter hood and accessories 247 kg)
Noise level	70 dBA (Noise-pressure level at 1 m distance, free-field measurement during operation)

2.7 Symbols on the machine



Operating instructions

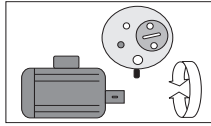

Phase inverter

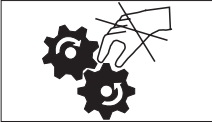

Danger! Do not put hands into running machine!

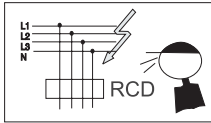

Operation via RCD circuit breaker only

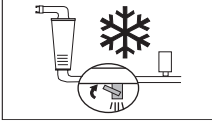

Drain water off under cold conditions!

2.8 Components supplied

The machine is fitted with the following standard items:

- Material trough incl. safety grid with bag opener
- Mixer motor
- Transport screw D30, pitch 40
- Mixer shaft
- 1 water hose 3/4" with GEKA coupling

3 Transport and Set-up



When transporting, assembling and dismantling the machine, the applicable national and international safety regulations and legislation must always be observed, even if such regulations and legislation are not explicitly mentioned in these instructions.

3.1 Transport



If the machine is being moved by crane or truck, always observe the following points:

- Before moving it, remove any material remaining in the material trough of the machine
- Lifting gear (e.g. rope or belt) must have a minimum load-bearing capacity of 400 kg.
- Attach belts in such a way that they cannot slip.



Fig. 6: Lifting points on the D30

3.2 Setting the machine up

When setting the machine up on the building site, always observe the following rules.

The machine must be set up on an even surface and secured against accidental movement.

The machine must be positioned in an area where no objects can fall onto it from above. If this is not possible, the machine must be protected by a roof.

The machine must be positioned in such a way that all its operating elements are freely accessible at all times.



4 Start-up



When transporting, assembling and dismantling and operating the machine, the applicable national and international safety regulations and legislation must always be observed, even if such regulations and legislation are not explicitly mentioned in these instructions.

Before every start-up, the Continuous-Flow Mixer D30 must be checked for damage to electric cables, water hoses, plugs and couplings. Any damage must be repaired before the machine is used.



When the machine is plugged into the power supply, do not put your hands into the machine or the mixing pipe. This may cause serious injury.

4.1 Electrical connection



The Continuous-Flow Mixer must be connected to a regulation site distributor box with RCD automatic circuit breaker. Use a 16A 5-pole 6h plug. The connecting cable must have a cross section of 5 x 2.5 mm² and a 16A fuse.

- Connect power cable with EEC plug to the infeed socket (fig. 7).



Fig. 7: Input socket with phase inverter

4.2 Water connection

To achieve an even mortar consistency, the machine requires a constant water pressure of 2 bars.

ATTENTION!

- Ensure that the water-infeed filter is in place and clean
- Connect the internal water hose (fig. 8, 3) to the mixing pipe (fig. 8, 2)
- Connect the exterior water hose with GEKA coupling
 - directly to the fitting (fig. 8, 4)
 - or, if in place
 - to the water pump (optional, fig. 8, 1)
- Turn on water supply

If the water supply is insufficient, use a water butt. The water-supply hose (3/4") must be vented completely beforehand.

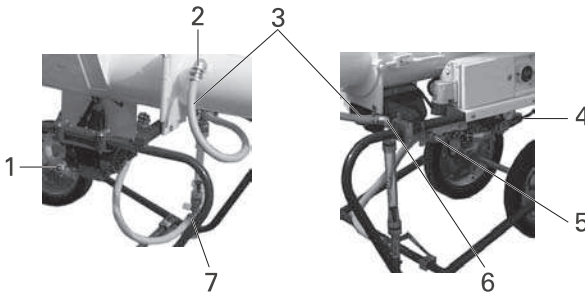

Fig. 8 : Water connection

- 1 Inlet, water pump (optional)
- 2 Inlet, mixing pipe
- 3 Interior water hose
- 4 Inlet, water fitting
- 5 Outlet, water fitting
- 6 Outlet, flow meter (optional)
- 7 Inlet, flow meter (optional)

4.3 Direction of rotation

ATTENTION!

Check the direction of rotation of the motor!

- Switch the main switch to "1". The machine goes on.
- Observe the rotation direction of the shaft in the material trough



Fig. 9: Direction arrow on mixing tube



The direction of rotation of the shaft must correspond to the direction of the arrow on the Continuous-Flow Mixer D30.

If the direction is incorrect, switch the machine to "0" immediately at the red main switch and pull out the power plug.

- Using a screwdriver, press the pole inverter in the infeed plug inwards and turn it 180°. The pole inverter must click back into position after being turned.
- Insert the power plug and start the machine up.

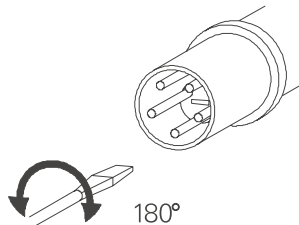

Fig. 10: Pole inverter in input plug

4.4 Setting water flow

- Place a bucket under the outlet
- Set the main switch to "1". The motor starts up and the solenoid valve on the water fitting opens. The water runs into the mixing pipe where it is mixed with the dry material
- Check the consistency of the mortar emerging from the outlet

Do not put your hands into the machine!

- If necessary, adjust the water flow at the fine-control valve (fig. 11, 1) on the water fitting.
- To increase the flow of water, turn the fine-control valve anticlockwise
- To decrease the flow of water, turn the fine-control valve clockwise
- For products, whose water requirement is not known, the machine should be started with the fine-control valve fully opened
- During operation, turn the fine-control valve back until the correct consistency is achieved.



Fig. 11: Water fitting

1 Fine-control valve

Always dispose of mortar residues as building waste!



5 Operation



When operating the machine, the applicable national and international safety regulations and legislation must always be observed, even if such regulations and legislation are not explicitly mentioned in these instructions.

Before every shift, the Continuous-Flow Mixer D30 must be checked for damage to electric cables, water hoses, plugs and couplings. Any damage must be repaired before the machine is used.



When the machine is plugged into the power supply, do not put your hands into the machine or the mixing pipe. This may cause serious injury.

5.1 Using material in bags

ATTENTION!

Do not overfill the material trough. Maximum content 3 x 40 kg.

- Tear open the bags on the grid of the material trough and allow the material to flow into the trough



Always dispose of empty bags in accordance with environmental regulations.

5.2 Using material from hopper

This function is only possible in combination with a filter hood (see section 9) and a conveyor unit.

Switch off the Continuous-Flow Mixer and pull out the power plug



- Remove the safety grid
- Mount the filter hood and connect the material hoses
- Connect to power supply and switch machine on at main switch

The Continuous-Flow Mixer is now supplied via the filter hood and conveyor. The conveyor is controlled by a rotary wing probe in the material trough.



Fig. 12: D30 with filter hood

5.3 Intervals in work

ATTENTION!

Intervals in work should be limited in length. Always keep the setting time of the mortar in mind. Hardened mortar in the mixing pipe causes difficulty in starting the motor and may damage the mixer permanently.

To prevent the mortar from setting, intervals should always be less than the setting time of the material. If the interval is longer than this, the Continuous-Flow Mixer must be cleaned (see page 28).

5.4 Operation in winter

ATTENTION!

The machine may be seriously damaged if the water in the fittings is allowed to freeze. At low temperatures, all the water fittings in the machine must be emptied. For longer intervals in work, ensure that the water fittings are completely emptied.

- Stop the flow of water
- Empty the supply hose to the water fitting or water pump (optional), the connection hose between pump and fitting and the water hose to and from the flow meter (optional)
- Open the draining valves of the water fitting (fig. 13, 1) and the flow meter (optional) (fig. 13, 2)

ATTENTION!

Close all the draining valves before starting the machine up again.

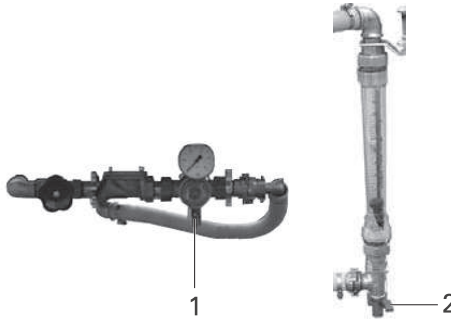

Fig. 13: Emptying the water fitting and the flow meter

- 1 Draining valve of water fitting
- 2 Draining valve of flow meter (optional)

5.5 Finishing work

- Allow the material trough to empty

Do not use thin or runny material. Allow it to run into a bucket and dispose it of correctly.

ATTENTION!

- Allow the portioning and mixing pipe to run empty
- Switch main switch to "0"
- Close off water supply

Dispose of mortar residues in the correct way.



6 Cleaning



Before cleaning the machine, always switch off the Continuous-Flow Mixer D30 and pull out the power plug!



Dispose of mortar residues in the correct way!

6.1 Cleaning after finishing work

- Uncouple the hose from the mixing pipe
- Release the eccentric catch on the mixing pipe (fig. 14, 2) and remove the bearing cover (fig. 14, 1)

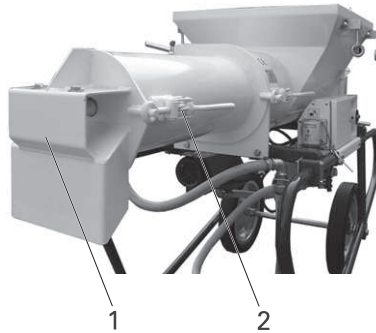

Fig. 14: Complete mixing pipe

- 1 Bearing cover
- 2 Eccentric catch "Mixing pipe"

- Remove mixing shaft (fig. 15, 1)
- Release the eccentric catch on the portioning pipe (fig. 15, 2)



Fig. 15: Mixing pipe

- 1 Mixing shaft
- 2 Eccentric catch "Portioning pipe"

- Fold mixing pipe back (fig. 16)



Fig. 16: Mixing pipe folded back

- 1 Shaft coupling
- 2 Portioning pipe
- 3 Material trough

- Keep the shaft coupling clean, dry and free of grease.
- Do not allow water to enter the material trough or the portioning tube.

Keep the shaft coupling (fig. 16, 1) clean, dry and free of grease.

ATTENTION!

Do not allow water to enter the material trough or the portioning tube.

- Clean bearing cover, mixing pipe, and mixing shaft with a water jet and brush
- Clean the portioning pipe (fig. 16, 2) in the dry state
- Re-assemble the machine in the opposite sequence

6.2 Cleaning before material change

- Proceed as described in section "Cleaning after finishing work"
- Release eccentric catch "Mixer motor" and fold mixer motor back
- Clean material trough without water
- Fold mixer motor back and lock into position



Fig. 17: Cleaning before material change

1 Eccentric catch "Mixer motor"

7 Maintenance

Before working on the machine, always switch it off and disconnect it from the mains electricity supply. Even when the machine is switched off, certain parts of it remain live.



The safe working condition of the machine must be verified in accordance with legal requirements (or at least once per year) by a specialist engineer. Use only spare parts and accessories supplied by m-tec. m-tec mathis technik gmbh will not accept liability for injury or damage caused by the use of non-approved spare parts and accessories.

- Remove mortar residues regularly from the mixing pipe and dispose of these correctly
- Check hoses and cable connections regularly to ensure that they are fit for use.

7.1 Lubrication plan

- Lubricate the grease points on the mixer motor and mixing pipe every 4–6 weeks with a high-pressure grease gun (1–2 shots) and bearing grease (fig. 18)
- Fill the rubber packing on the mixer motor regularly with a grease gun.



Fig. 18: Lubrication points

1 Socket pin

7.2 Oil change

ATTENTION!

Do not top up with gear oil between oil changes. If the machine is overfilled with oil, it may overheat. Never mix different types of oil. This may cause the oils to decompose and lead to irreparable damage to the gear unit.



When disposing of oil, grease and cleaning agents, always comply with the environmental regulations in force.

The gear motors are maintenance-free up to 8000 hours of operation. They should then be cleaned thoroughly with a suitable flushing oil and the oil then changed.

We recommend the following type of oil for the gear motor: **Shell Tivela Oil 82; quantity 400 cc.**

If you are unable to obtain the lubricant named above, there are a number of possible alternatives:

ARAL	Degol BG 220
BP	Energol GR-x P220
CALYPSOL	Bisol Oil MSR 114
ESSO	Sparton EP-220
HOUGHTON	Molygear 115
MOBIL	Mobilgear 630
SHELL	Omala 220

7.3 Maintenance of water filters

The water filters in the water fitting or water pump should be cleaned every 4 - 6 weeks. These filters are located in the water inlet (fig. 19, 1) and pressure reducer (fig. 19, 2).

- Remove filters with the special key (fig. 19, 3)
- Clean the filters under running water
- Blow out the filters with compressed air
- Replace the filters and secure the connections

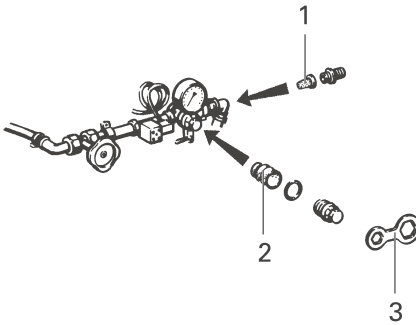

Fig. 19: Cleaning filters

- 1 Filter in water inlet
- 2 Filter in pressure reducer
- 3 Special key

8 Troubleshooting



The Troubleshooting Table is not intended to replace the detailed instructions in the appropriate sections of these Operating Instructions. Always comply with the safety notes in each section!

Problem	Cause	Remedy
Mixer motor does not run	No power	Check power connection and fuses
	Mortar hardened in mixing pipe	Clean mixing pipe (see section 6.1)
	Motor safety switch triggered	Open switch cabinet, check safety switch (fig. 20)
No water	Overload safety switch may have triggered	Check motor safety switch "mixer motor" (fig. 20, 1)
	Solenoid valve does not open	Coil may be defective, replace solenoid valve
Mortar too dry	Too little water	Check water supply. The pressure must be at least 2 bars. If necessary, install a water pump (available as accessory for the D30, see section 9)
	Overload safety switch of water pump (option) has triggered	Check motor safety switch "water pump" (fig. 20, 2)
	Water-flow valve not open enough	Open valve further (see section 4.4)
Mortar too thin	Too much water	Close water flow valve further (see section 4.4)

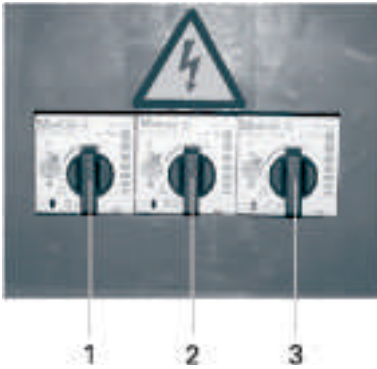

Fig. 20: Overload fuses in switch cabinet

- 1 Motor safety switch "Mixer motor"
- 2 Motor safety switch "Water pump" (optional)
- 3 Fuse prim. 400 V / sec. 42 V

Problem	Cause	Remedy
Consistency of material varies	Filter in pressure re-ducer or inlet filter clogged	Clean filters (see section 7.3)
	Fabric of filter hood (optional) clogged with dust particles	Beat out filter hood (optional)

9 Spare parts/accessories



Use only spare parts and accessories supplied by m-tec. m-tec mathis technik gmbh will not accept liability for injury or damage caused by the use of non-approved spare parts and accessories.

9.1 Accessories

The field of application and the handling of the Continuous-Flow Mixer can be considerably improved by using m-tec accessories. The following accessories are available for this machine

- Connection cable 5 x 1,5 mm²,
50 m, 400 V (16A 5pol 6h) 570024
- Water pump 400 V incl. attachment 566020
- Filter hood incl. accessories 565670
- Conveyor screw D30 pitch 30 565060
- Conveyor screw D30 pitch 50 565057
- Conveyor screw D30 pitch 70 565052
- Additional water pump AD33, 230 V 1ph 601351
- Suction hose 3/4", 4 m complete 601185
- Water hose 3/4", 20 m with GEKA
flow meter, complete 565025
- Tarpaulin for material trough 565138

9.2 Spare parts

For spare parts, please refer to our spare-parts catalogue. Send orders to:

m-tec mathis technik gmbh, Sales Dept.:

Tel. no.: ++49 / 7631 / 709-112 or -216

Fax no.: ++49 / 7631 / 709-116

10 Circuit diagram

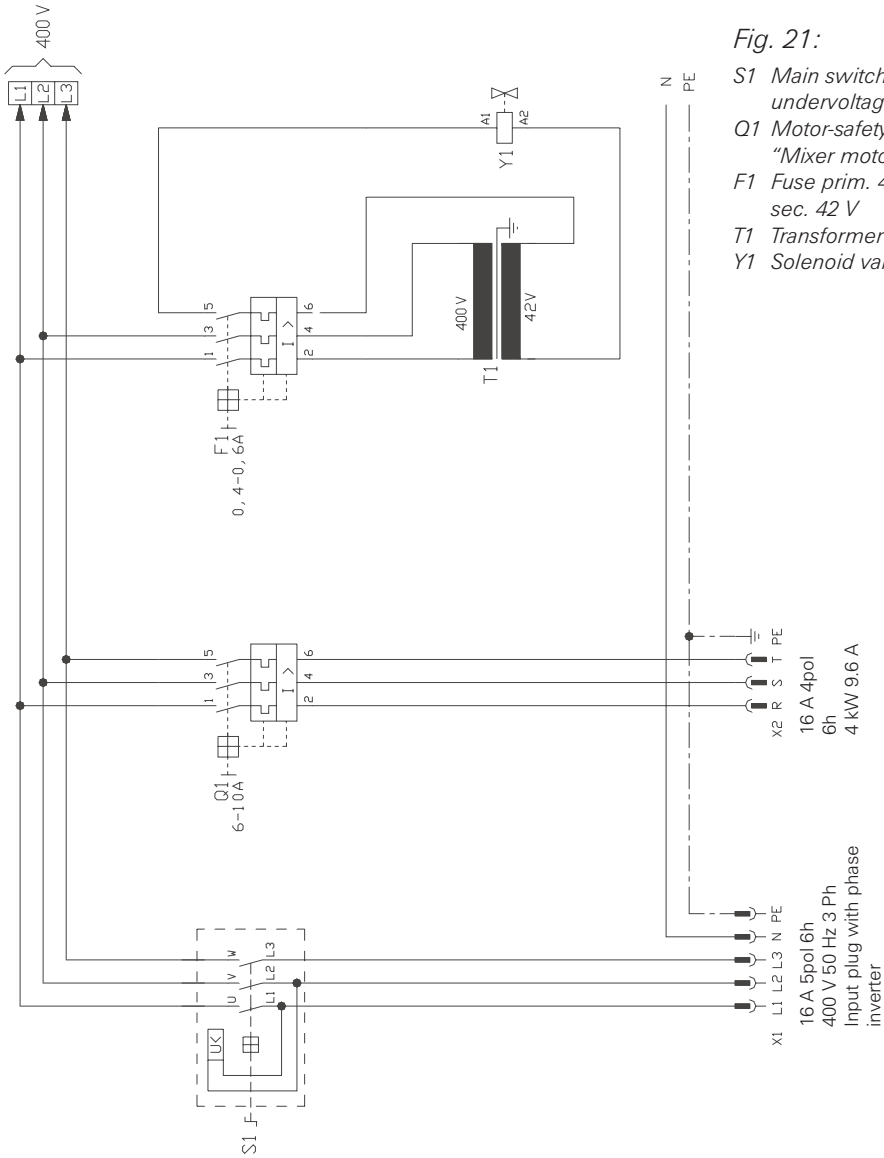

Fig. 21:

- S1 Main switch with undervoltage trigger
- Q1 Motor-safety switch "Mixer motor"
- F1 Fuse prim. 400 V / sec. 42 V
- T1 Transformer
- Y1 Solenoid valve

Fig. 21: Circuit diagram D30

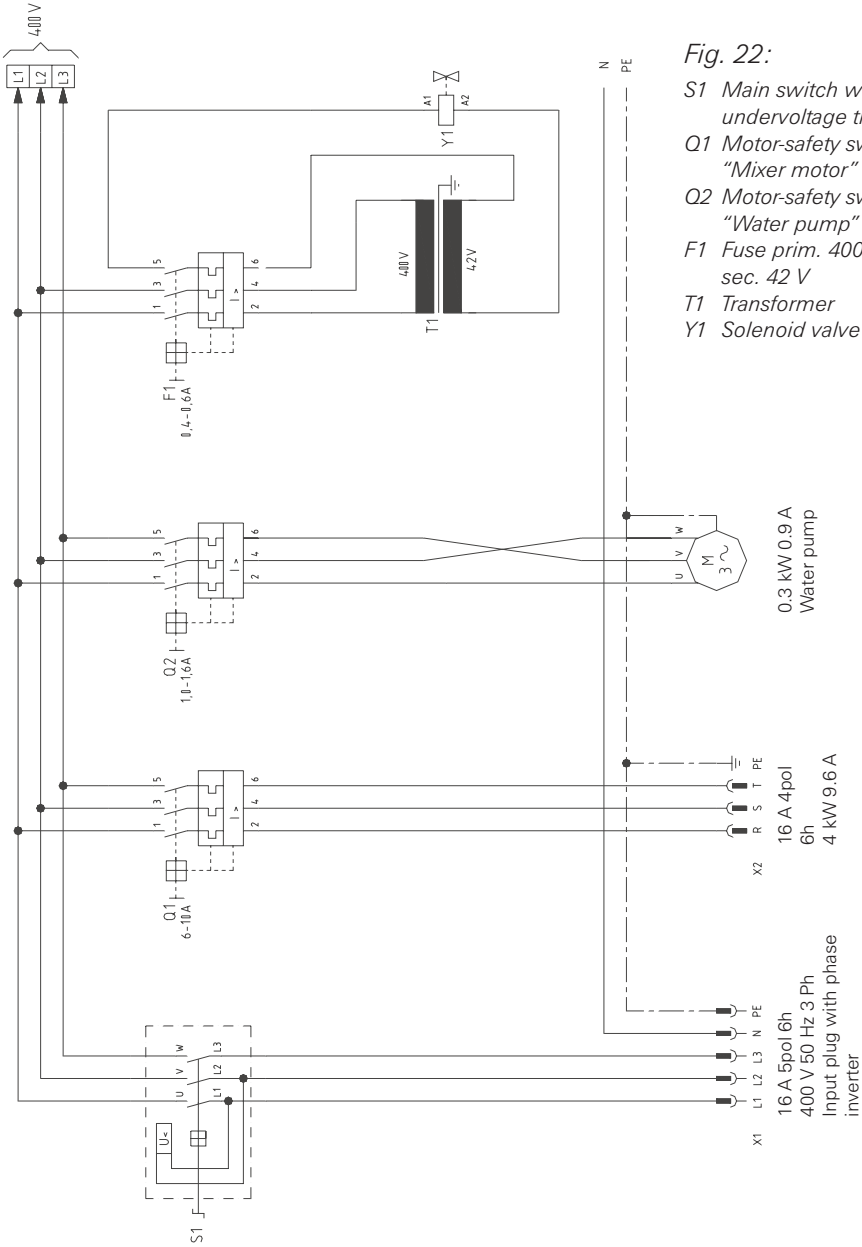

Fig. 22:
 S1 Main switch with undervoltage trigger
 Q1 Motor-safety switch "Mixer motor"
 Q2 Motor-safety switch "Water pump"
 F1 Fuse prim. 400 V / sec. 42 V
 T1 Transformer
 Y1 Solenoid valve

Fig. 22: Circuit diagram D30 with water pump

D30 - 392595 - 10/2000



